

Specifications

DESCRIPTION

- Solid brass construction
- Premium finish resist corrosion and tarnishing
- Anti-scald pressure balance valve
- Ultra-thin shower head with air injection technology
- Handshower with backflow protection
- 59" PVC hose for enhanced flexibility
- Diverter knob switch water between shower head and handshower

FLOW

- Shower head maximum 2 gpm (7.6 L/min)
- Handshower maximum 2 gpm (7.6 L/min)

CARTRIDGE

- Ceramic disk cartridge
- Pressure-balanced valve

WARRANTY

- Lifetime limited warranty against leaks, drips and finish defects from the original date of purchase. (Improper care and cleaning will void the warranty)
- 5-year warranty if used in commercial installations

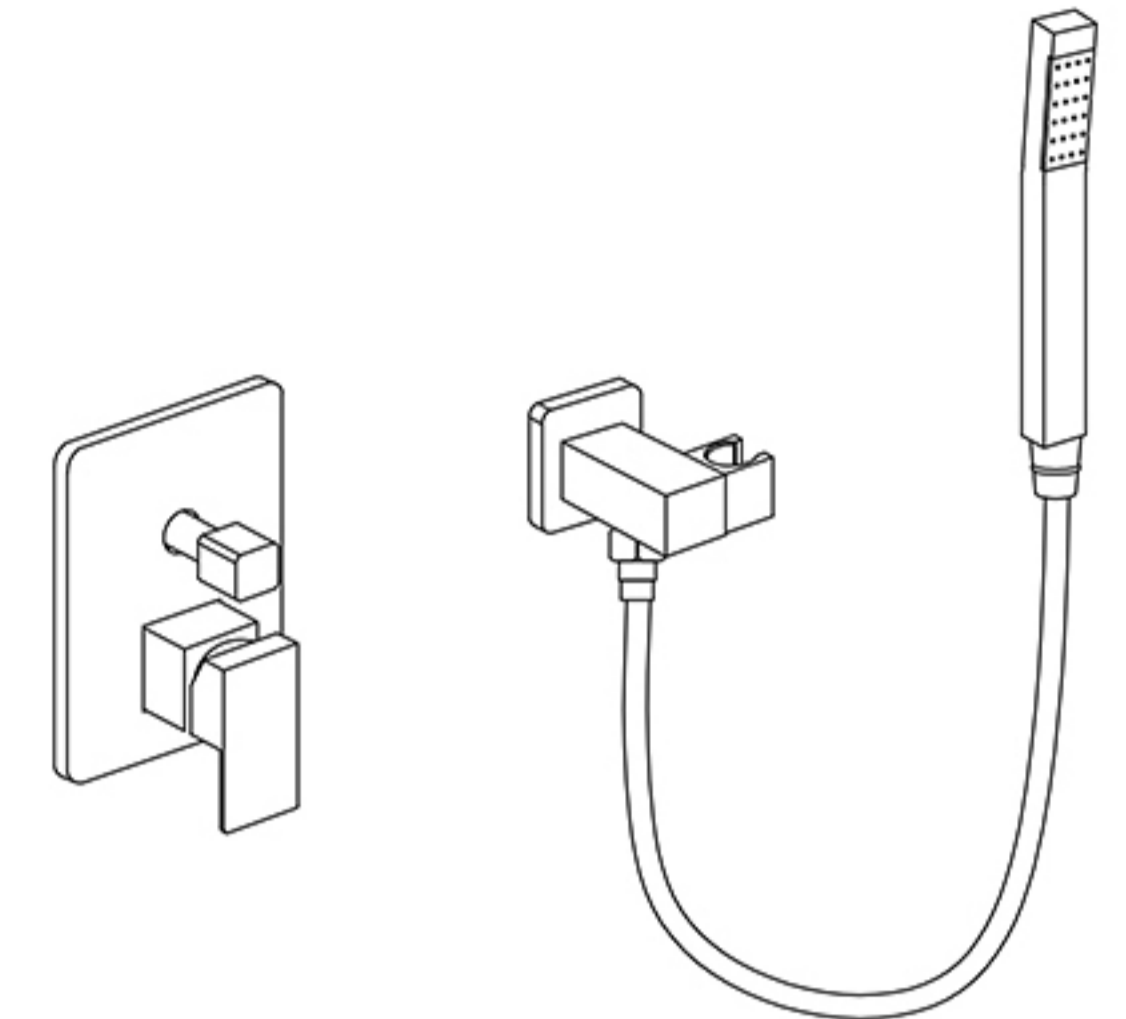
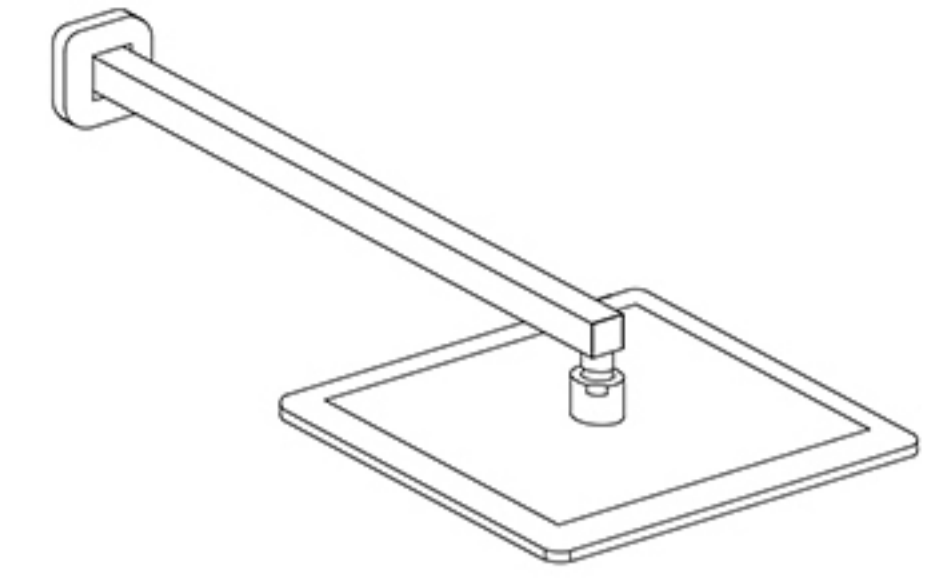

Wall Mount Shower System # HMUS-020012

NOTE: THIS SHOWER SYSTEM IS DESIGNED TO BE INSTALLED WITH 1/2" NPT CONNECTION.

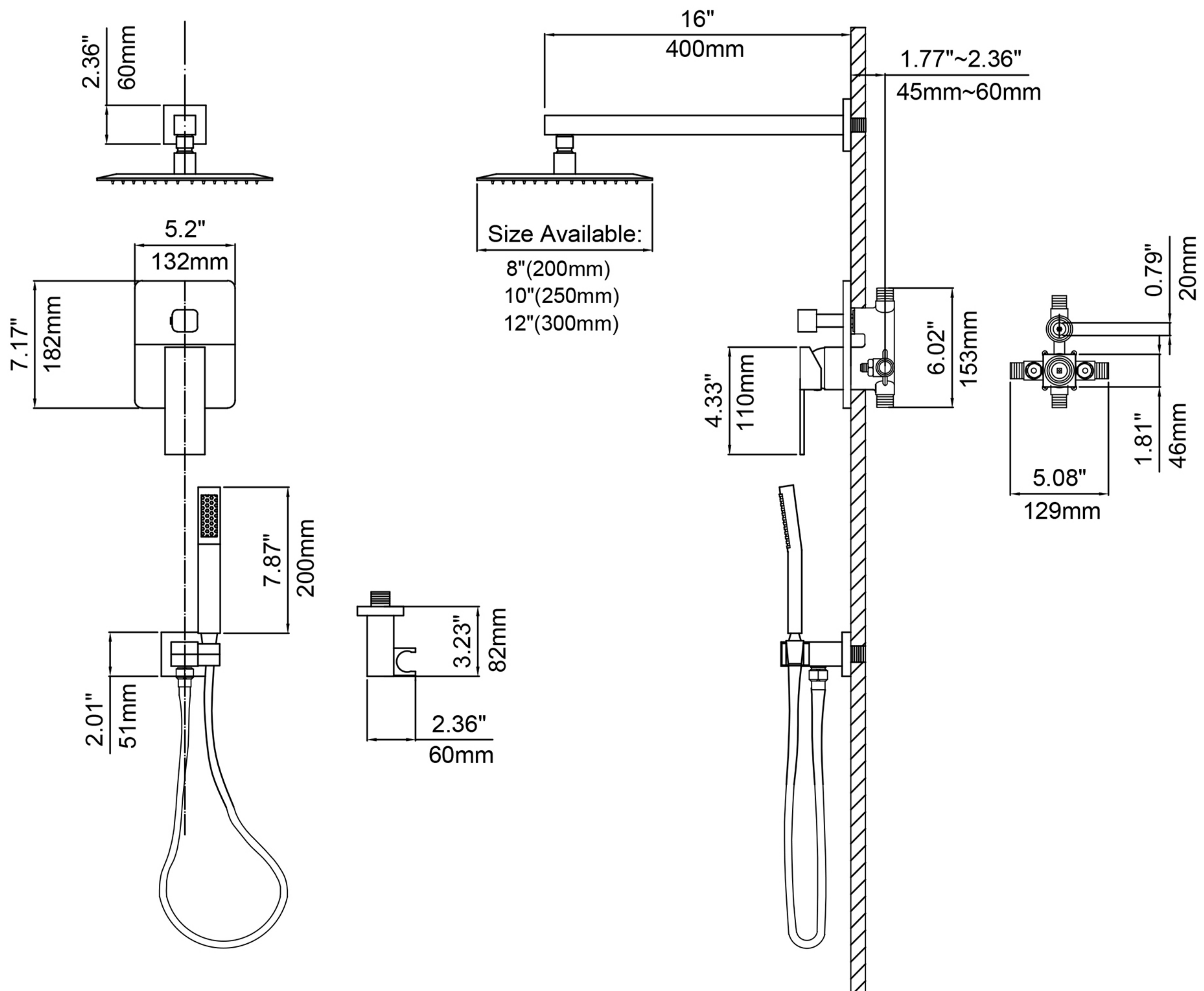

CRITICAL DIMENSIONS